

Industrial Lever Hoist TR7

The TR7 industrial unit is an economical option without compromising quality. Lightweight, compact and rugged construction with the handle, gear case and brake cover made entirely of pressed steel, producing strong resistance to impact damage. Using only the highest quality materials precisely machined throughout ensures the TR7 is the ideal hoist for long term use with less maintenance and servicing costs.

Each unit comes fully certified with a test certificate or an EC Declaration of Conformity stating compliance with the essential health and safety requirements of the Machinery Directive 2006/42/EC. This document clearly states the proof test at 1.5 times the rated capacity and the light load test of 2% of the rated capacity, which exceeds the requirements of the current applicable standard.

- Rugged steel body construction
- Lightweight and portable
- 360 degree handle rotation
- Short stroke and low lever pulling effort
- Easy single-hand "freewheeling" operation
- Drop forged & heat treated alloy hooks
- Highest quality alloy, calibrated load chains in Grade 80 (T) or 100 (V). Also available with stainless steel load chain.
- Safe reliable twin pawl mechanical brake
- Guaranteed light load protection
- Heat treated alloy steel triple spur gears and pinion shaft
- Operating temperature of -40°C to +50°C (-40°F to +122°F)
- Light load testing at maximum of 2% rated capacity
- Ultimate strength test, at least 4 times the Working load limit (WLL)
- 5' height of lift as standard but can be chained to exact requirements
- Individual spares readily available
- Meets or exceeds all the requirements within BS EN 13157: 2004+A1:2009, ANSI/ASME B30.21, AS1418.2 and SANS 1636.

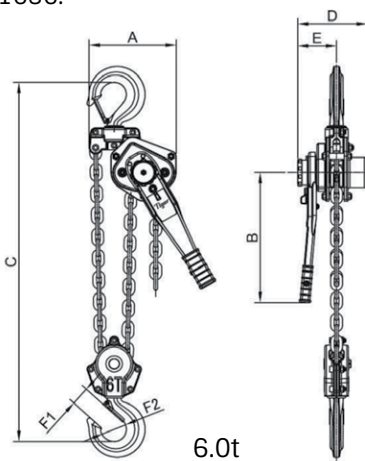
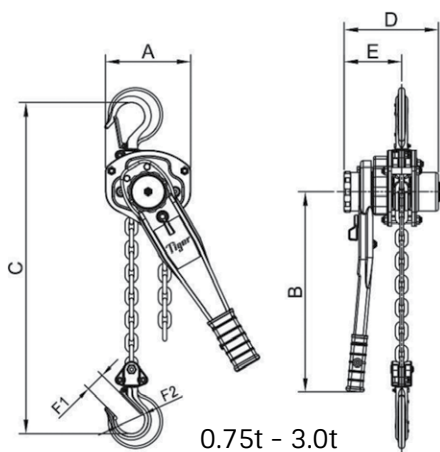

Product Code	Capacity (ton, T)	Effort (kg, lb)	Dimensions (mm, in)							Load Chain		Std. Lift (ft)	Unit weight w/ standard lift (lb)	Adder weight per additional ft of lift (lb)
			A	B	C	D	E	F1	F2	Diameter (mm)	No. of falls			
TR7LH-0075	0.75, 0.83	23, 51	128, 5	240, 9	275, 11	158, 6	99, 4	24, 1	38, 1	Ø6.3	1	5	17	0.6
TR7LH-0100	1.0, 1.1	29, 64	128, 5	236, 9	295, 12	158, 6	99, 4	28, 1	45, 2	Ø6.3	1	5	17	0.6
TR7LH-0150	1.5, 1.65	26, 57	154, 6	360, 14	320, 13	172, 7	104, 4	34, 1	51, 2	Ø7.1	1	5	22	0.7
TR7LH-0200	2.0, 2.2	35, 77	154, 6	360, 14	320, 13	172, 7	104, 4	34, 1	51, 2	Ø7.1	1	5	24	0.7
TR7LH-0300	3.0, 3.3	38, 84	182, 7	360, 14	400, 16	195, 8	108, 4	36, 1	56, 2	Ø10.0	1	5	40	1.5
TR7LH-0600	6.0, 6.6	40, 88	242, 10	360, 14	570, 22	195, 8	108, 4	49, 2	70, 3	Ø10.0	2	5	65	2.9